

Synchronous Reference Frame Theory (SRF) along with PI Controller Based Dynamic Voltage Restorer

P Ananda Mohan¹ M Sandeep²

^{1,2}EEE Department, SreeDattha Institute of Engineering & Science

ABSTRACT: The problem of voltage sags and swells and its major impact on sensitive loads are well known. To solve this problem, custom power devices are used. One of those devices is the Dynamic Voltage Restorer (DVR), which is one of the most efficient and effective modern custom power devices used in power distribution networks. A new control algorithm for the DVR is proposed in this paper to regulate the load terminal voltage during sag, swell in the voltage at the point of common coupling (PCC). This new control algorithm is based on synchronous reference frame theory (SRF) along with PI controller is used for the generation of reference voltages for a dynamic voltage restorer (DVR). These voltages, when injected in series with a distribution feeder by a voltage source inverter (VSI) with PWM control, can regulate the voltage at the load terminals against any power quality problem in the source side. It first analyzes the power circuit of the system in order to come up with appropriate control limitations and control targets for the compensation voltage control through the DVR. The control of the DVR is implemented through derived reference load terminal voltages. The proposed control scheme is simple to design. Simulation results carried out by MATLAB with its Simulink and Sim Power System (SPS) toolboxes to verify the performance of the proposed method.

Keywords: Power Quality, DVR, voltage sags/swells, VSI, Synchronous Reference Frame Theory, MATLAB/SIMULINK.

I. INTRODUCTION

Power distribution systems, ideally, should provide their customers with an uninterrupted flow of energy at smooth sinusoidal voltage at the contracted magnitude level and frequency [1] however, in practice, power systems, especially the distribution systems, have numerous nonlinear loads, which significantly affect the quality of power supplies. As a result of the nonlinear loads, the purity of the waveform of supplies is lost. This ends up producing many power quality problems. Apart from nonlinear loads, some system events, both usual (e.g. capacitor switching, motor starting) and unusual (e.g. faults) could also inflict power quality problems[2]. Power quality phenomenon or power quality disturbance can be defined as the deviation of the voltage and the current from its ideal waveform. Faults at either the transmission or distribution level may cause voltage sag or swell in the entire system or a large part of it. Also, under heavy load conditions, a significant voltage drop may occur in the system. Voltage sag and swell can cause sensitive equipment to fail, shutdown and create a large current unbalance. These effects can incur a lot of expensive from the customer and cause equipment damage [1]. The voltage dip magnitude is ranged from 10% to 90% of nominal voltage and with duration from half a cycle to 1 min and *swell* is defined as an increase in rms voltage or current at the power frequency for durations from 0.5 cycles to 1 min. There are many different methods to mitigate voltage sags and swells, but the use of a custom power device is considered to be the most efficient method, e.g. FACTS for transmission systems which improve the power transfer capabilities and stability margins. The term custom power pertains to the use of power electronics controller in a distribution system [10], especially, to deal with various power quality problems. Custom power assures customers to get pre-specified quality and reliability of supply. This pre-specified quality may contain a combination of specifications of the following: low phase unbalance, no power interruptions, low flicker at the load voltage, and low harmonic distortion in load voltage, magnitude and duration of over voltages and under voltages within specified limits, acceptance of fluctuations, and poor factor loads without significant effect on the terminal voltage. There are different types of Custom Power devices used in electrical network to improve power quality problems. Each of the devices has its own benefits and limitations. A few of these reasons are as follows. The SVC pre-dates the DVR, but the DVR is still preferred because the SVC has no ability to control active power flow [3]. Another reason include that the DVR has a higher energy capacity compared to the SMES and UPS devices. Furthermore, the DVR is smaller in size and cost is less compared to the DSTATCOM and other custom power devices. Based on these reasons, it is no surprise that the DVR is widely considered as an effective custom power device in mitigating voltage sags. In addition to voltage sags and swells compensation, DVR can also add other features such as harmonics and Power Factor correction. Compared to the other devices, the DVR is clearly considered to be one of the best economic solutions for its size and capabilities [4] The organization of the paper is as follows. The operating principle and the voltage injection capabilities of the DVR is discussed in section II, proposed control algorithm

enumerated in section III and the detailed description of MATLAB Simulation model along with its performance in electrical network discussed in section IV and section V respectively.

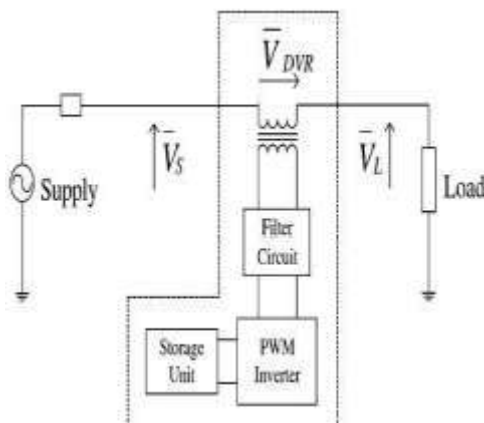

Figure-1: DVR series connected topology

II. OPERATION OF DVR

The schematic diagram of a DVR is shown in Figure-2. Three phase source voltages (V_{sa} , V_{sb} , and V_{sc}) are connected to the 3-phase critical load through series impedance (Z_a , Z_b , Z_c) and an injection transformer in each phase. The terminal voltages (V_{ta} , V_{tb} , V_{tc}) have power quality problems and the DVR injects compensating voltages (V_{ca} , V_{cb} , V_{cc}) through an injection transformer to get undistorted and balanced load voltages (V_{La} , V_{Lb} , V_{Lc}). The DVR is implemented using a three leg voltage source inverter with IGBTs along with a dc capacitor (C_{dc}). A ripple filter (L_r , C_r) is used to filter the switching ripple in the injected voltage. The considered load, sensitive to power quality problems is a three-phase balanced lagging power factor load. A self-supported DVR does not need any active power during steady state because the voltage injected is in quadrature with the feeder current. Error signal is used as a modulation signal that allows generating a commutation pattern for the power switches (IGBT's) constituting the voltage source converter. The commutation pattern is generated by means of the sinusoidal pulse width modulation technique (SPWM); voltages are controlled through the modulation. The speed of the response is determined by parameters K , K_p and K_v . These parameters control transient as well as steady state behavior of the filter. There exists harmonics and the oscillatory components of voltages are eliminated using low pass filters (LPF).

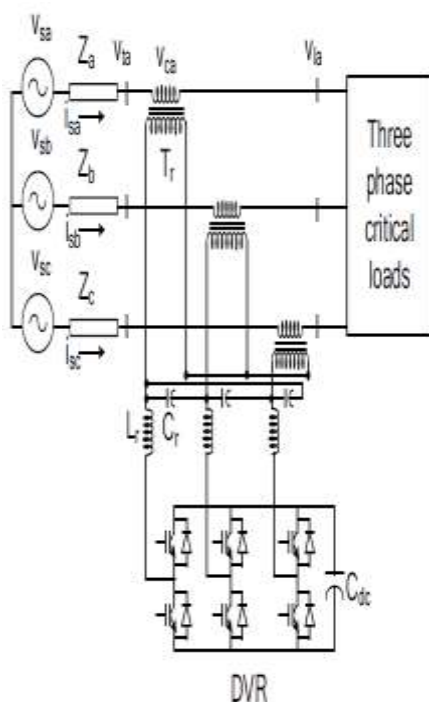

Figure-2 (a)Schematic diagram of DVR

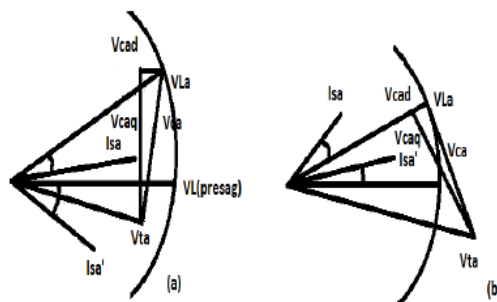

Figure-3: Phasor Diagram for (a) Voltage Sag (b) Voltage Swell

The DVR operation for the compensation of sag, swell in supply voltages is shown in Figure-3. Before sag the load voltages and currents are represented as VL (presag) and I_{sa} as shown in Figure-3(a). After the sag event, the terminal voltage (V_{ta}) is gets lower in magnitude and lags the presag voltage by some angle. The DVR injects a compensating voltage (V_{Ca}) to maintain the load voltage (VL) at the rated magnitude. V_{Ca} has two components, V_{Cad} and V_{Caq} . The voltage in-phase with the current (V_{Cad}) is required to regulate the dc bus voltage and also to meet the power loss in the VSI of DVR and an injection transformer [5]. The voltage in quadrature with the current (V_{Caq}) is required to regulate the load voltage (V_L) at constant magnitude. During swell event, the injected voltage (V_{Ca}) is such that the load voltage lies on the locus of the circle as shown in Figure-3(b).

III. CONTROL OF DVR

The compensation for voltage sags using a DVR can be performed by injecting/absorbing reactive power or real power. When the injected voltage is in quadrature with the current at the fundamental frequency, compensation is achieved by injecting reactive power and the DVR is self-supported with dc bus. But, if the injected voltage is in phase with the current, DVR injects real power and hence a battery is required at the dc side of VSI. The control technique adopted should consider the limitations such as the voltage injection capability (inverter and transformer rating) and optimization of the size of energy storage . Figure-4 shows the control block of the DVR in which the synchronous reference frame (SRF) theory is used for the control of self-supported DVR. The voltages at PCC (V_i) are converted to the rotating reference frame using the abc-dqo conversion. The harmonics and the oscillatory components of voltages are eliminated using low pass filters (LPF). The components of voltages in d-axis and q-axis are, $V_{sd} = V_{sd} dc + V_{sd} acV_{sq} = V_{sq} dc + V_{sq} ac$ The compensating strategy for compensation of voltage quality problems considers that the load terminal voltage should be of rated magnitude and undistorted

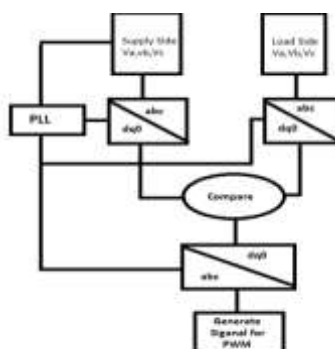

Figure-4: Control Block of DVR

The dqo transformation or Park's transformation [6] is used to control of DVR. The dqo method gives the sag depth and phase shift information with start and end times. The quantities are expressed as the instantaneous space vectors. Firstly convert the voltage from a-b-c reference frame to d-q-o reference. For simplicity zero phase sequence components is ignored. The control is based on the comparison of a voltage reference and the measured terminal voltage (V_a , V_b , V_c).The voltage sags is detected when the supply drops below 90% of the reference value whereas voltage swells is detected when supply voltage increases up to 25% of the reference value. The error signal is used as a modulation signal that allows generating a commutation pattern for the power switches (IGBT's) constituting the voltage source converter. The commutation pattern is generated by means of the sinusoidal pulse width modulation technique (SPWM); voltages are controlled

through the modulation. The speed of the response is determined by parameters K , K_p and K_v . These parameters control transient as well as steady state behavior of the filter. There exists a compromise between speed and accuracy. For large K and K_p , K_v , the convergence of the estimated values to actual values is faster but the steady state maladjustment is higher. This is an inherent characteristic of an adaptive algorithm. Parameters ought to be selected appropriately according to the application. Increasing the value of K increases the speed. However, it creates oscillations in the peak detection response. There is a trade-off between speed and accuracy (or smoothness). Decreasing K and K_p , K_v yields an estimation of the peak which is insensitive / robust to the undesirable variations and noise in the input signal. The presented PLL provides the following advantages online estimation of the amplitude, phase and their corresponding time derivatives of the pre-selected component of the input signal are provided.

IV. MATLAB MODELLING AND SIMULATION

The DVR is modeled and simulated using the MATLAB and its Simulink and Sim Power System toolboxes. The MATLAB model of the DVR connected system is shown in fig.5 below. The three-phase programmable source is connected to the three-phase load through the DVR in order to generate sag, swell and harmonics in supply side. The considered load is a lagging power factor load. The VSI of the DVR is connected to the system using an injection transformer. In addition, a ripple filter for filtering the switching ripple in the terminal voltage is connected across the terminals of the secondary of the transformer. The dc bus capacitor of DVR is selected based on the transient energy requirement and the dc bus voltage is selected based on the injection voltage level. The dc capacitor decides the ripple content in the dc voltage. In particular, tripping of equipment in a production line can cause production interruption and significant costs due to loss of production. One solution to this problem is to make the equipment itself more tolerant to sags, either by intelligent control or by storing “ride-through” energy in the equipment.

An alternative solution, instead of modifying each component in a plant to be tolerant against voltage sags, is to install a plant wide uninterruptible power supply system for longer power interruptions or a DVR on the incoming supply to mitigate voltage sags for shorter periods. DVRs can eliminate most of the sags and minimize the risk of load tripping for very deep sags, but their main drawbacks are their standby losses, the equipment cost, and also the protection scheme required for downstream short circuits.

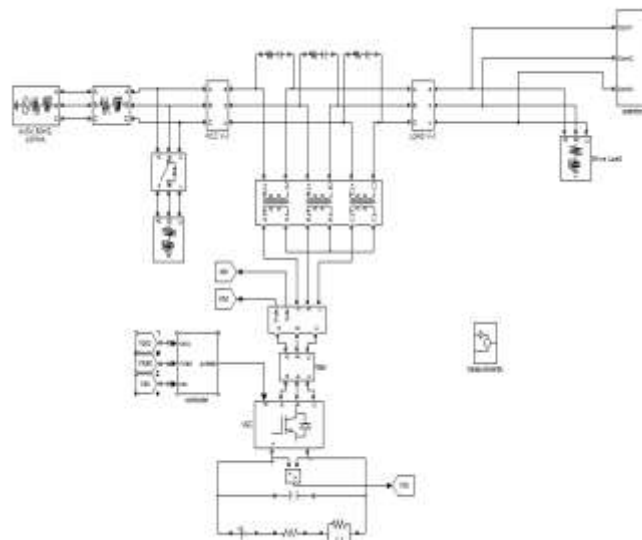

Figure-5: MATLAB model of DVR connected system

The control algorithm for the DVR is simulated in MATLAB. The reference load voltages are derived from the sensed terminal voltages, load supply voltages and the dc bus voltage of the DVR. A pulse width modulation (PWM) controller is used over the reference and sensed load voltages to generate gate signals for the IGBT's of the VSI.

V. SIMULATION RESULTS

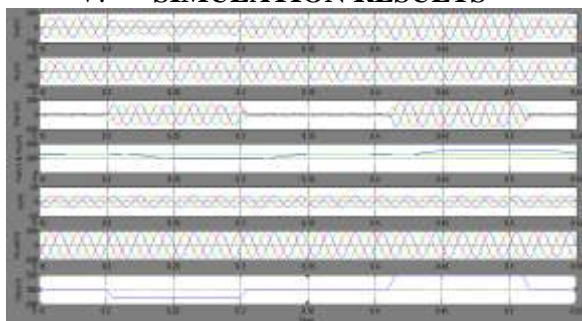

FIG. 6 Dynamic performance of DVR with in-phase injection during voltage sag and swell applied to critical load.

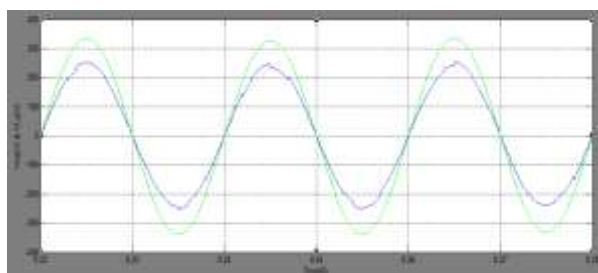
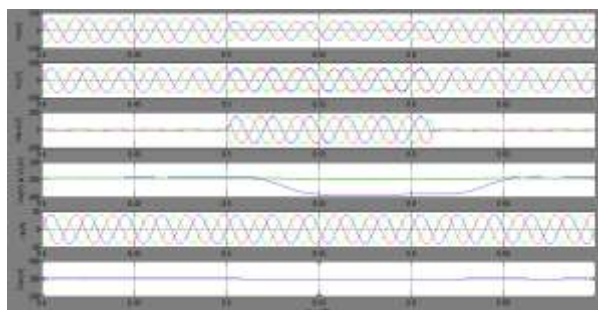
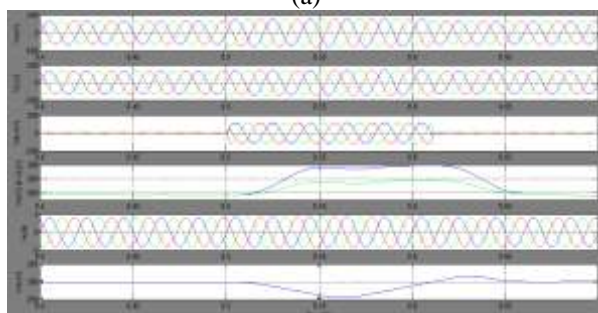

FIG7. Voltages at the PCC and load terminals



(a)



(b)

FIG.8 Dynamic performance of the capacitor-supported DVR during (a) voltage sag and (b) voltage swell applied to critical load.

VI. CONCLUSION

The conventional sag detection method is unable to detect the voltage sags lower than a definite level. As an instance, a single phase to ground fault resulting voltage sag cannot be determined by this method because the method used the average of the three phase voltage and sees the single phase voltage sag as an average value of three phases. To overcome the disadvantages of the conventional sag detection method, the proposed method is used in this paper. With the proposed method, the controller is able to detect different types of power quality problems without an error and injects the appropriate voltage component to correct immediately any abnormality in the terminal voltage to keep the load voltage balanced and constant at the nominal value. Simulation and experimental results show that, the proposed DVR successfully protects the most critical load against voltage sags.

REFERENCES

- [1]. Power Quality Problems and New Solutions by A. de Almeida, L. Moreira. J. Delgado
- [2]. Math H.J. Bollen, Understanding power quality problems: voltage sags and interruptions, IEEE Press, NewnYork, 2000
- [3]. Performance of DVR under different voltage sag and swell conditions by T. Devaraju, V. C. Reddy and M. Vijaya Kumar
- [4]. Voltage Quality Improvement Using DVR by Chellali BENACHAIBA, Brahim FERDI
- [5]. Adaline-Based Control of Capacitor Supported DVR for Distribution System Bhim Singh*, P. Jayaprakash†, and D. P. Kothari